

1

INSTALL THE BRACKETS

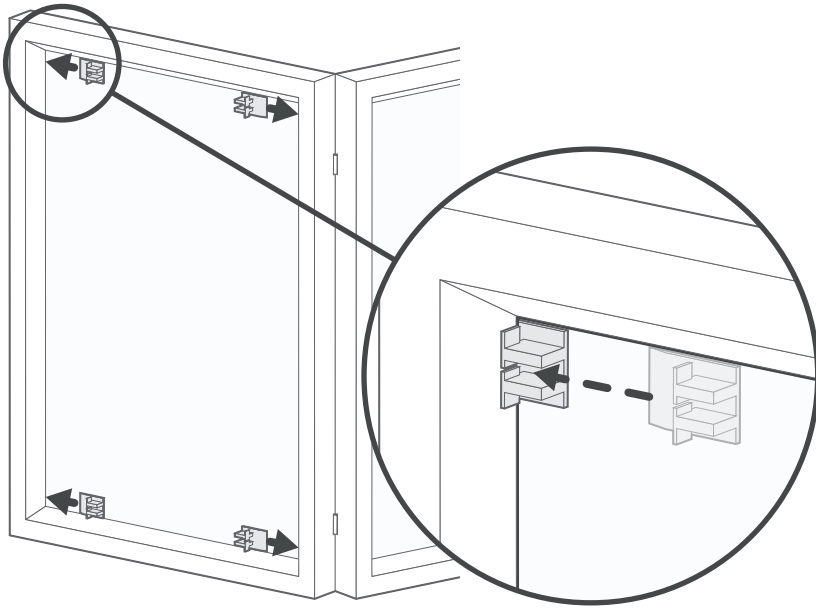

Place the brackets flat to the glass and push them in towards the frame, ensuring that they slide in under the rubber/mastik seal. Push in each bracket as far as possible, with one bracket in each corner of the glass.

2

INSTALL THE BLIND

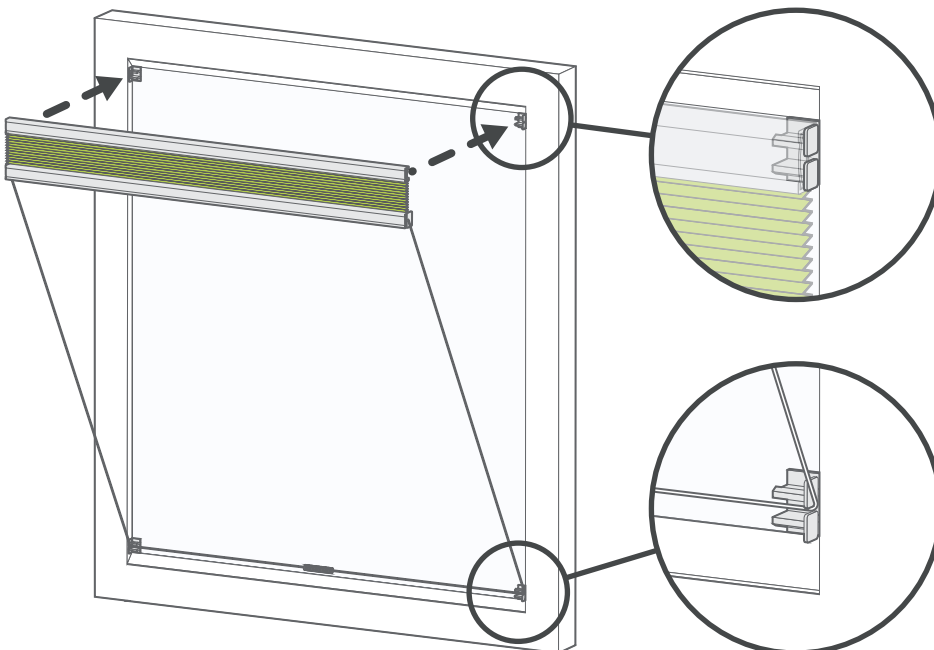

Clip the headrail onto the brackets at the top of the window by aligning the rail with the brackets and pushing the rail back towards the glass until you hear it click into place.

Hook the cord through the centre of the lower bracket on both sides of the window. The cord should be running straight down the edge of the glass, hooking around the bracket. Make sure it's passing through the centre of the bracket and then straight across the bottom of the window.

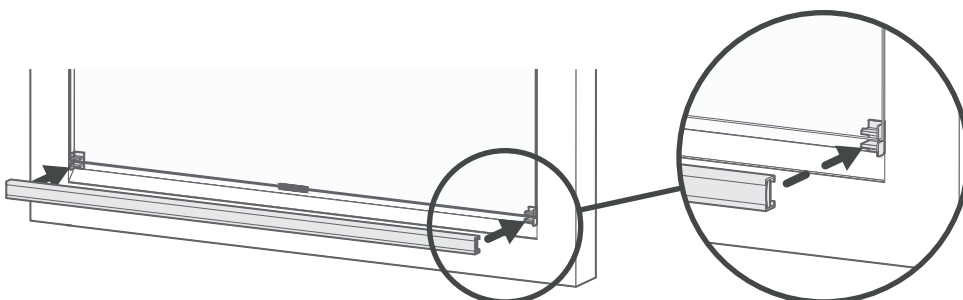

To finish, clip the bottom rail into the lower brackets by aligning the rail with the brackets and pushing back firmly towards the glass, until the rail clicks into place.

Continued on Next Page

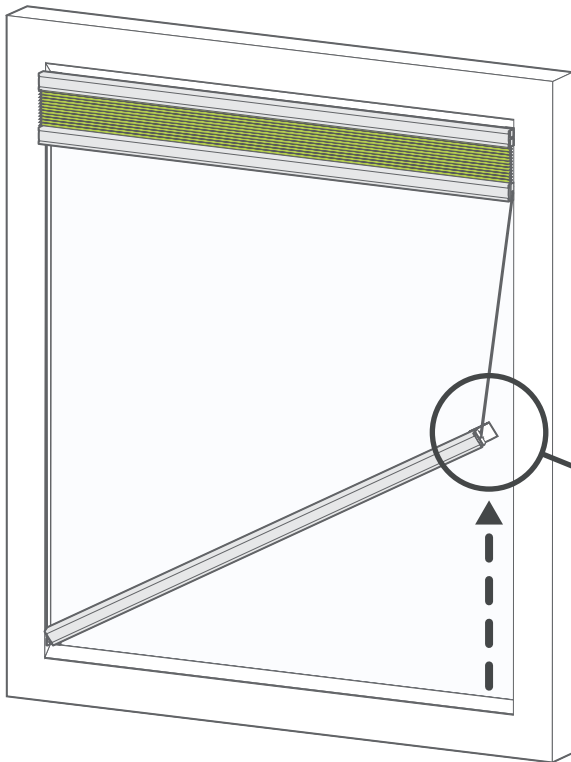

Over time the cords may slacken off and require re-tensioning. You'll know if the blind needs re-tensioning as it will begin to slip back down of its own accord when raised.

Start by removing the bottom rail – to do this, slide it upwards from one corner, to slide the bracket out from under the seal.

Then, remove the brackets from both ends of the rail and put the rail to one side.

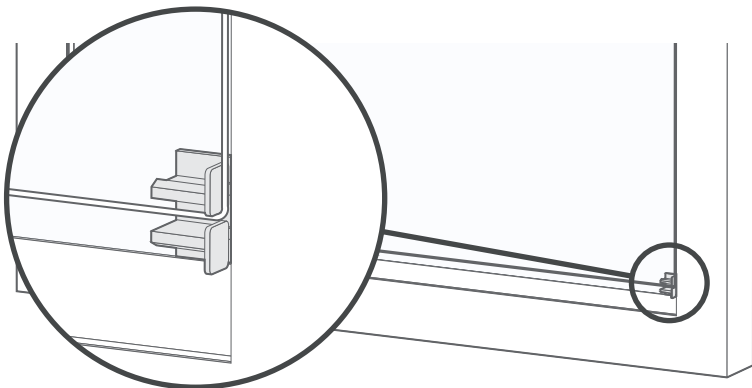
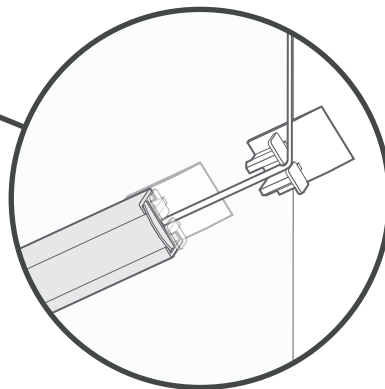

Slot the brackets back into the corners, as per step 1 of this guide.

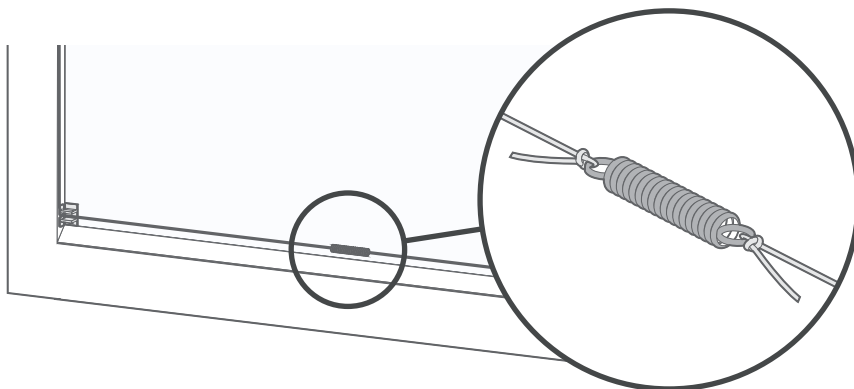

At the bottom of the blind the cord is connected to both ends of a small spring. Untie the knot at one side of the spring.

Pull the end of the cord through by 5-10mm, then give the blind a test to see if the tension is right. Repeat this as necessary until the tension is correct.

Once you're done, simply click the bottom rail back into place as per step 2 of this guide.