

The brackets offer three methods of installation:

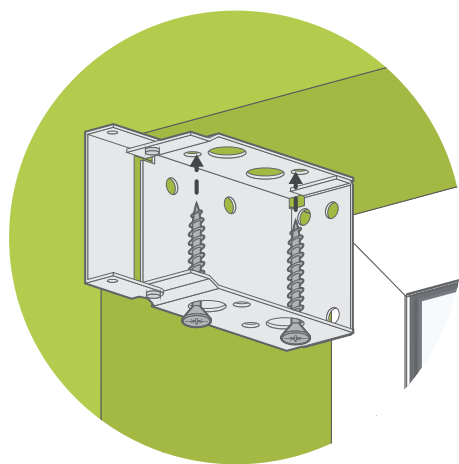

**Top-Fix**

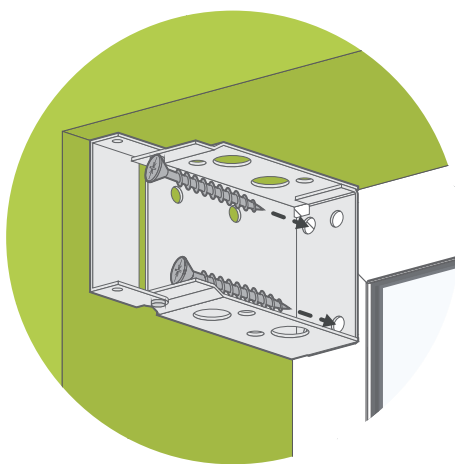

**Face-Fix**

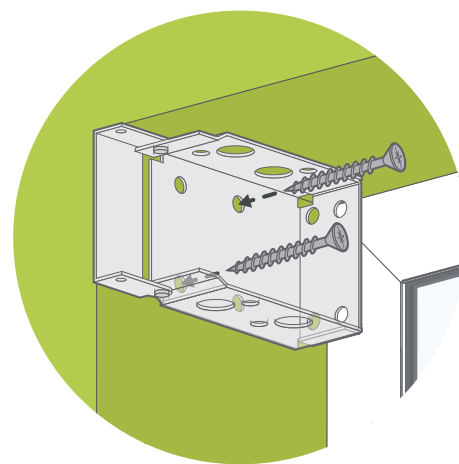

**Side-Fix**

Wider blinds will be supplied with support brackets. These should be positioned towards the centre of the window area in-line with the box brackets. Make sure that the position of the support bracket is clear of any cords coming out of the headrail. Support brackets can be top-fixed or face-fixed.

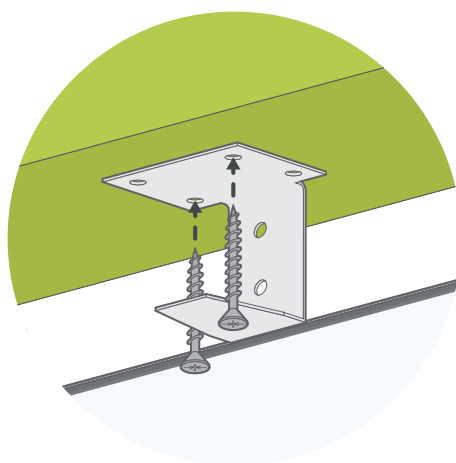

**Top-Fix**

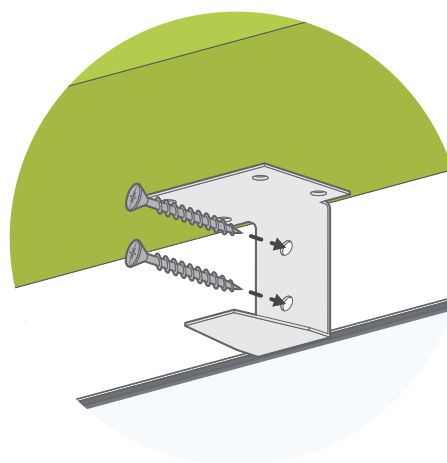

**Face-Fix**

2

### INSTALL THE BLIND

If you are fitting the blind inside a recess, go to step 3 before step 2.

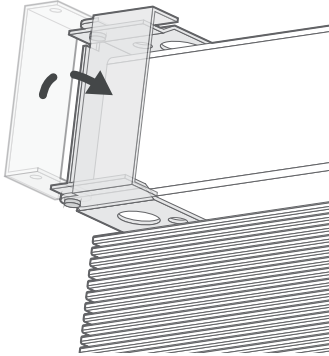

Lift the blind to the window and slot the headrail into the open brackets.

Swing the hinged section of the bracket closed and press firmly until it locks.

#### Top Tip

If you pull the cords to tilt the blind but the slats do not move:

- Make sure the slats are open and that the tilt cords are both the same length.
- Stack the blind up tightly and lock it off, then take it down from the brackets.
- Push the metal rod inside the headrail all the way over to the left, so that it is connected to the tilting mechanism.

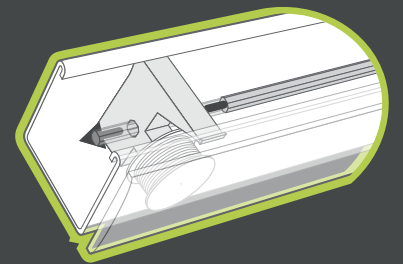

3

### INSTALL THE PELMET

Attach the winged clips to the rear of the pelmet and hook the serrated pelmet clips onto the headrail (if installing the blind within a recess, this should be done before step 2) so that both the serrated clips and winged clips are in corresponding positions on the headrail and pelmet. Then align the two clips with each other and apply gentle pressure to the front of the pelmet, directly over the clips to click them together.

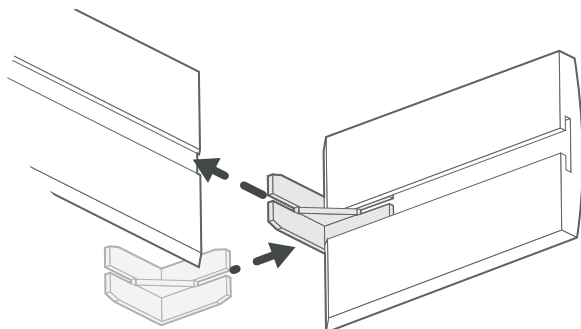
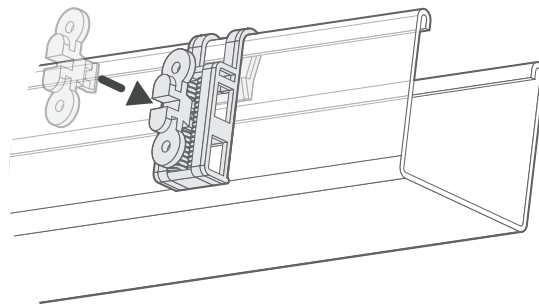
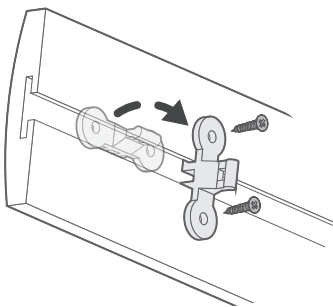

#### Pelmets for 'Exact Fitting'

If you've ordered 'exact fitting' then the pelmet will be sent wider and mitred at the ends, with additional end returns to cover the brackets. Use the 'L' shaped plastic brackets from your fittings pack to attach the side returns to the pelmet.

#### Cord Condenser

A breakaway cord condenser is pre-fitted to the lift cords so that when a horizontal force is applied to the cords above the condenser, it safely breaks away to eliminate any hazardous loops in the cords.

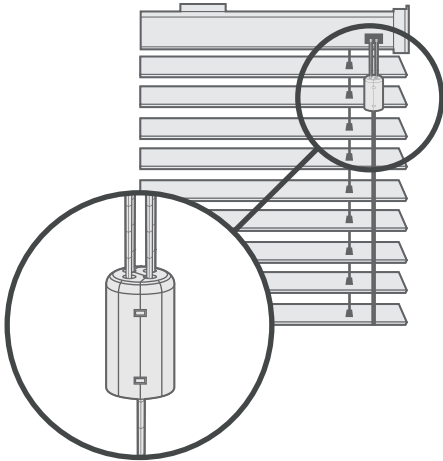

If the cord condenser is pulled apart:

Untangle and untwist the cords.

For 2 cords: press the cord condenser together until it is fully closed.

For 3 cords: Place the loose cord in the opening in one half of the cord condenser and press the cord condenser together until it is fully closed.

For 4 cords: Place one of the loose cords in the opening of one half of the condenser, the remaining loose cord in the opening in the other half, then press the cord condenser together until it is fully closed.

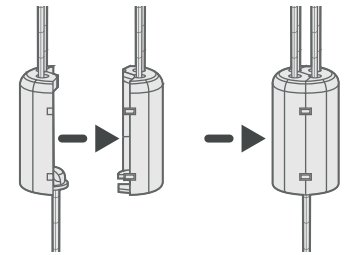
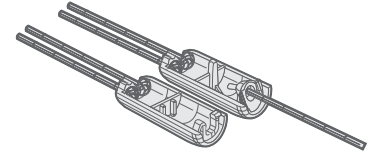

#### Cord Safety Cleat

The safety cleat shall be installed as close as possible to the blind's headrail and in all cases not less than 1500mm from the floor. The cord must be fully accumulated around the safety cleat(s) when the blind is not in use. Use the table below to determine the distance required between the cleats to fully accumulate the cords when the blind is fully raised.

Drop of blind	*Distance between cord cleats (centre to centre)
1-1000mm	100mm
1001-2000mm	150mm
2001-3000mm	300mm

Place the safety cleat in the desired position on the wall and mark the positions of the holes with a pencil.

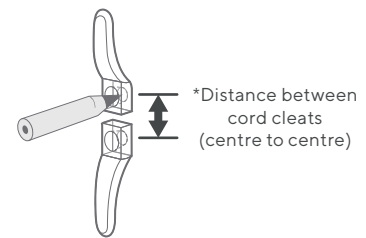

Mark the hole positions and drill as required. Use the screws provided to attach the safety cleat to the wall.

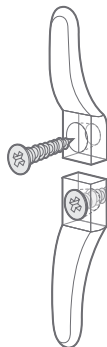

Wrap the cords around the cord cleats in a figure of 8. When the cords are fully accumulated, ensure they are secure so that when any cord is pulled, no excess cord is released.

